



Technická data	SGB 150	SGB 240	SGB 250	SGB 360	
Chlazení	plynem chlazené	plynem chlazené	plynem chlazené	plynem chlazené	
CO ₂	180 A	250 A	230 A	320 A	
Směsný plyn	150 A	220 A	200 A	290 A	
Zatěžovatel	60 %	60 %	60 %	60 %	
Průměr drátu	0,6 - 1,0	0,8 - 1,2	0,8 - 1,2	0,8 - 1,2	
Min. průtok chladicí kapaliny	-	-	-	-	
Min. vstupní tlak chl.kapaliny	-	-	-	-	
Min. požad. výkon chlazení	-	-	-	-	
Max. vstupní tlak chl.kapaliny	-	-	-	-	
Max. vstupní teplota chl.kapaliny	-	-	-	-	
Obj. čísla	3M 4M 5M	SGB15-3 SGB15-4 SGB15-5	SGB24-3 SGB24-4 SGB24-5	SGB25-3 SGB25-4 SGB25-5	SGB36-3 SGB36-4 SGB36-5

Suregrip™ Ergo MIG/MAG hořáky

150A do 550A



Technická data	SGB 240W	SGB 401W	SGB 501W	SGB 555W	
Chlazení	vodou chlazené	vodou chlazené	vodou chlazené	vodou chlazené	
CO ₂	300 A	400 A	500 A	550 A	
Směsný plyn	270 A	350 A	450 A	500 A	
Zatěžovatel	60 %	100 %	100 %	100 %	
Průměr drátu	0,8 - 1,2	0,8 - 1,2	1,0 - 1,6	1,0 - 1,6	
Min. průtok chladicí kapaliny	1,2 l/min	1,2 l/min	1,2 l/min	1,2 l/min	
Min. vstupní tlak chl.kapaliny	2,0 bar	2,0 bar	2,0 bar	2,0 bar	
Min. požad. výkon chlazení	900 W	1 000 W	1 200 W	1 500 W	
Max. vstupní tlak chl.kapaliny	5,0 bar	5,0 bar	5,0 bar	5,0 bar	
Max. vstupní teplota chl.kapaliny	50 °C	50 °C	50 °C	50 °C	
Obj. čísla	3M	SGB24W-3	SGB401-3	SGB500-3	SGB555-3
	4M	SGB24W-4	SGB401-4	SGB500-4	SGB555-4
	5M	SGB24W-5	SGB401-5	SGB500-5	SGB555-5

SGB 150

Plynem chlazený svařovací hořák MIG

Jmenovitý proud: 180A CO₂, 150A směsný plyn, EN60974-7 @ DZ = 60%, Ø drátu 0,6 do 1,0mm

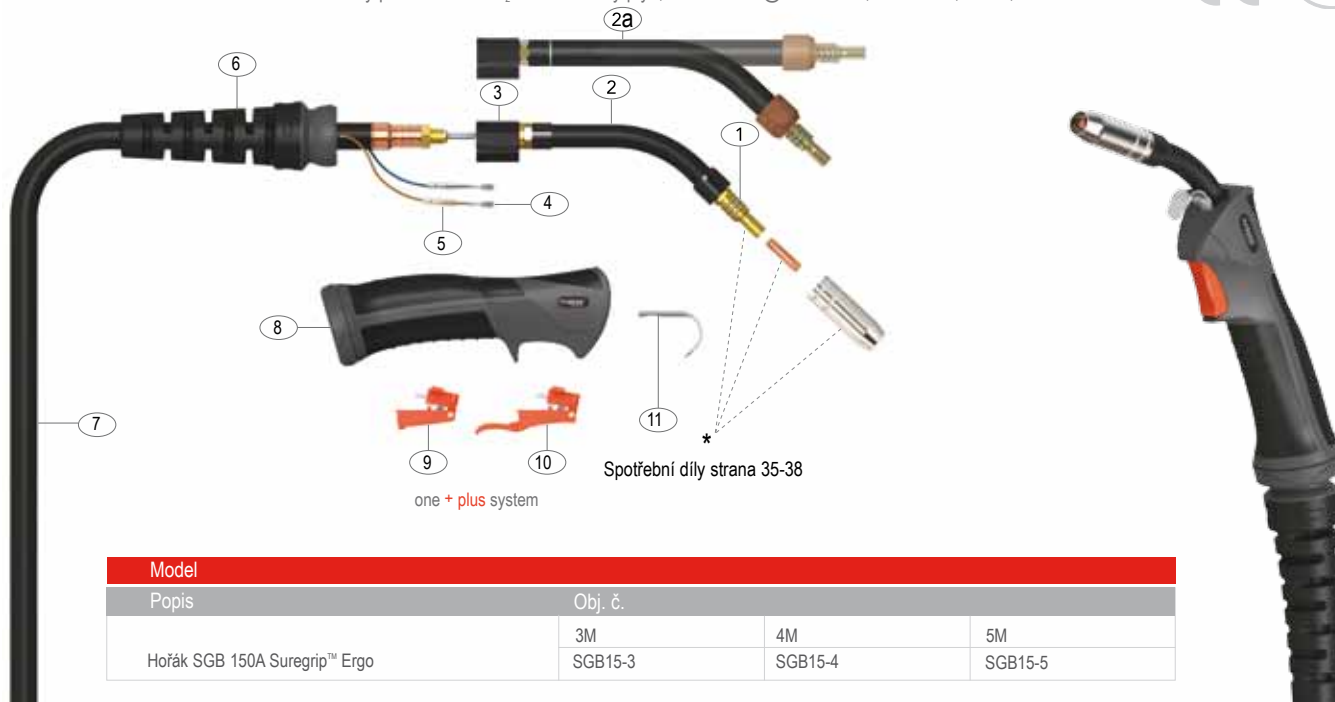

Model			
Popis	Obj. č.		
Hořák SGB 150A Suregrip™ Ergo	3M	4M	5M
	SGB15-3	SGB15-4	SGB15-5

Náhradní díly			
Obj. č.	Popis	Obj. č.	Popis
1	PB1504	16	SC2578/S
	Pružina		Kryt C/W
2	PE1501	17	PBL1541
	Trubka hořáku		Šroub
2a	PF1501	18	PC1519/P
	Trubka hořáku flexibilní		Matice
3	PG1515	19	PB1523
	Mezikus		Konektor Female
4	PB1521	20	PC1528
	Kabel - terminal		Zástrčka centrální
5	PB1521-C	21	PB1524
	Kabel - krytka konektoru		„O“ kroužek
6	PG8015	22	PB1525
	Ochrana kabelu		Matice bovdeny
7	PS1517-30		
	Kabel koax. X 3m		
	PS1517-40		
	Kabel koax. X 4m		
	PS1517-50		
	Kabel koax. X 5m		
8	SGB2514		
	Rukojeť ERGO		
9	DGB2516		
	Tlačítko standard		
10	DGB2516L		
	Tlačítko prodloužené		
11	PB2517		
	Hák závěsný		
12	PC2841		
	Chráníč kabelu		
13	PB1505		
	Matice pojistná		
14	PB1522		
	Kabel - terminal Male		
15	SCSP1-1		
	Šroub krytu		

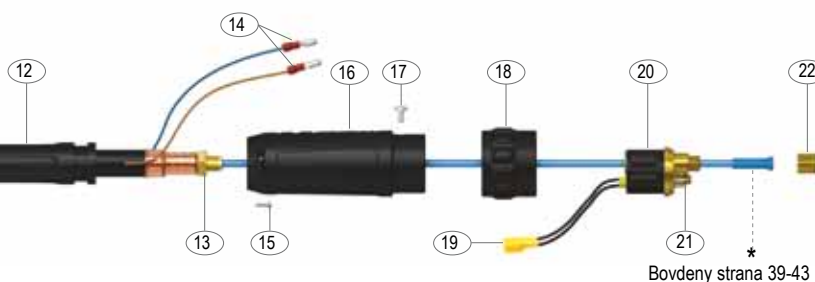

Suregrip™ Ergo MIG/MAG hořák

PARKER
TORCHOLOGY

SGB 240

Plynem chlazený svařovací hořák MIG

Jmenovitý proud: 250A CO₂, 220A směsný plyn, EN60974-7 @ DZ = 60%, Ø drátu 0,8 do 1,2 mm

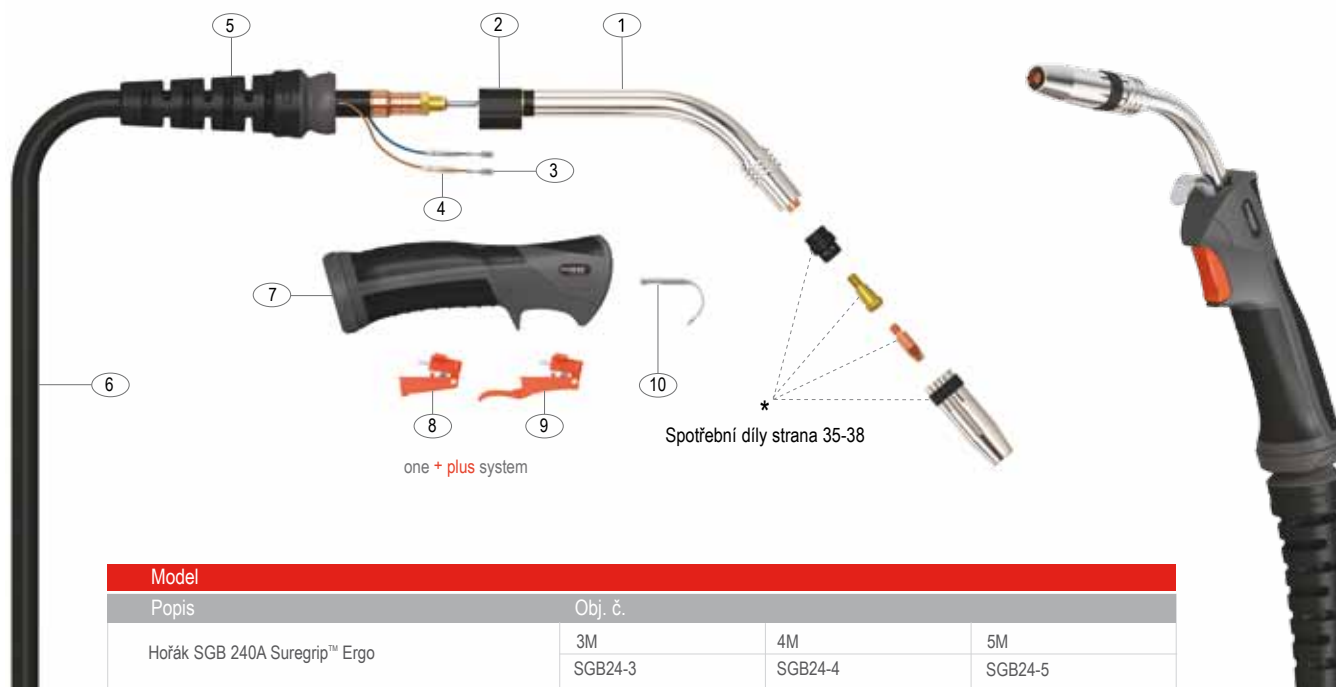

Model			
Popis	Obj. č.		
Hořák SGB 240A Suregrip™ Ergo	3M	4M	5M
	SGB24-3	SGB24-4	SGB24-5

Náhradní díly					
Obj. č.	Popis	Obj. č.	Popis		
1	PG2401	Trubka hořáku	15	SC2578/S	Kryt C/W
2	PG1515	Mezikus	16	PBL1541	Šroub
3	PB1521	Kabel - terminal	17	PC1519/S	Matice
4	PB1521-C	Kabel - krytka konektoru	18	PB1523	Konektor Female
5	PG8015	Ochrana kabelu	19	PC1528	Zástrčka centrální
6	PS2403-30	Kabel koax. X 3m	20	PB1524	„O“ kroužek
	PS2403-40	Kabel koax. X 4mt	21	PB1525	Matice bovdeny
	PS2403-50	Kabel koax. X 5m			
7	SGB2514	Rukojeť ERGO			
8	DGB2516	Tlačítko standard			
9	DGB2516L	Tlačítko prodloužené			
10	PB2517	Hák závěsný			
11	PC2841	Chráníč kabelu			
12	PB1505	Matice pojistná			
13	PB1522	Kabel - terminal Male			
14	SCSP1-1	Šroub krytu			

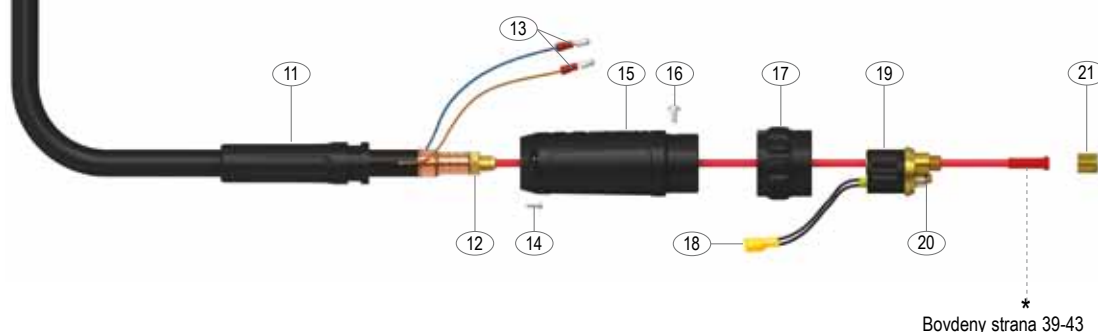

* Bovdeny strana 39-43



ALFA IN a.s., technická podpora
a centrální sklad pro Českou republiku a Slovensko

www.alfain.eu

obchod@alfain.eu

tel. 568 840 009

SGB 250

Plymem chlazený svařovací hořák MIG

Jmenovitý proud: 230A CO₂, 200A směsný plyn, EN60974-7 @ DZ = 60%, Ø drátu 0,8 do 1,2 mm

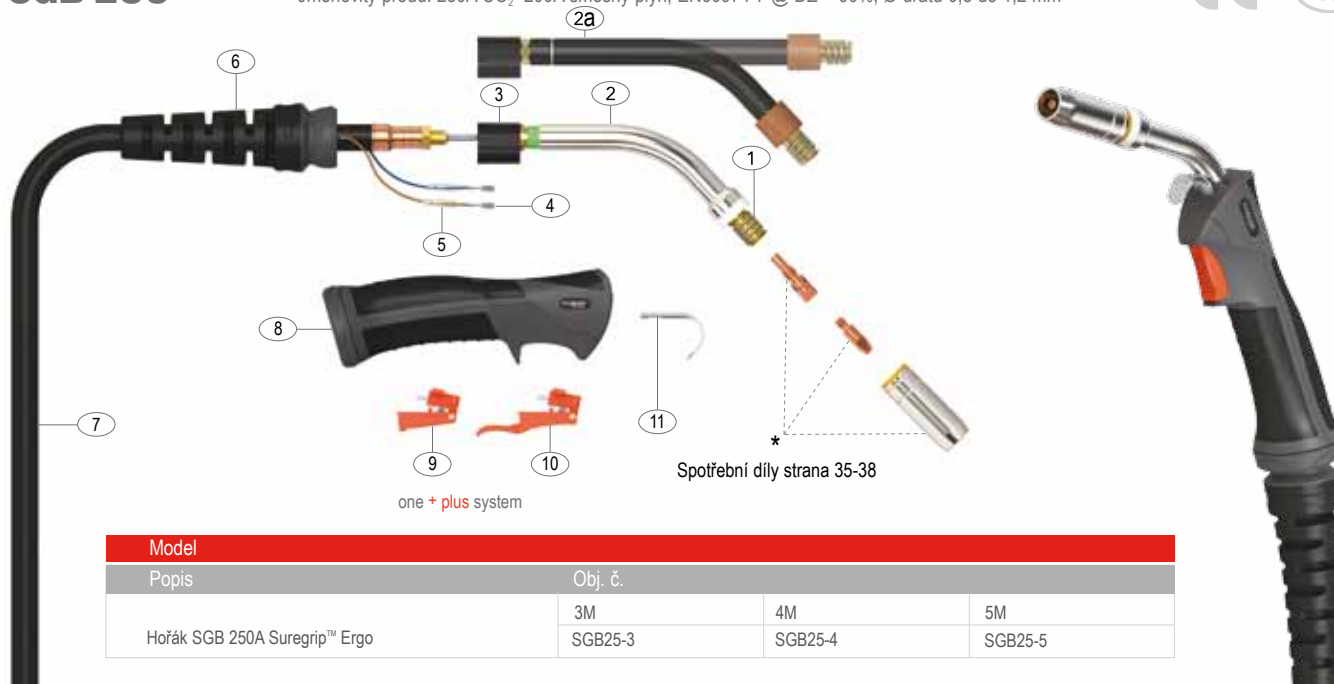

Model			
Popis	Obj. č.		
Hořák SGB 250A Suregrip™ Ergo	3M SGB25-3	4M SGB25-4	5M SGB25-5

Náhradní díly			
Obj. č.	Popis	Obj. č.	Popis
1	PB2502	16	SC2578/S
	Pružina	17	PBL1541
2	PG2501		Šroub
	Trubka hořáku	18	PC1519/S
2a	PF2501		Matice
	Trubka hořáku flexibilní	19	PB1523
3	PG1515		Konektor Female
	Mezikus	20	PC1528
4	PB1521		Zástrčka centrální
	Kabel - terminal	21	PB1524
5	PB1521-C		„O“ kroužek
	Kabel - kryt konektoru	22	PB1525
6	PG8015		Matice bovdeny
	Ochrana kabelu		
7	PS2503-30		
	Kabel koax. X 3m		
	PS2503-40		
	Kabel koax. X 4m		
	PS2503-50		
	Kabel koax. X 5m		
8	SGB2514		
	Rukojeť ERGO		
9	DGB2516		
	Tlačítko standard		
10	DGB2516L		
	Tlačítko prodloužené		
11	PB2517		
	Hák závěsný		
12	PC2841		
	Chráníč kabelu		
13	PB1505		
	Matice pojistná		
14	PB1522		
	Kabel - terminal Male		
15	SCSP1-1		
	Šroub krytu		

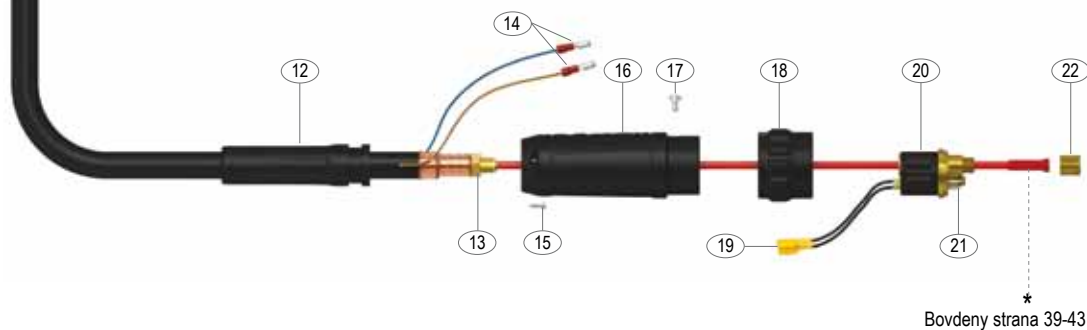

Suregrip™ Ergo MIG/MAG hořák

PARKER
TORCHOLOGY

SGB 360

Plynem chlazený svařovací hořák MIG
Jmenovitý proud: 320A CO₂ 290A směsný plyn, EN60974-7 @ DZ = 60%, Ø drátu 0,8 do 1,2 mm

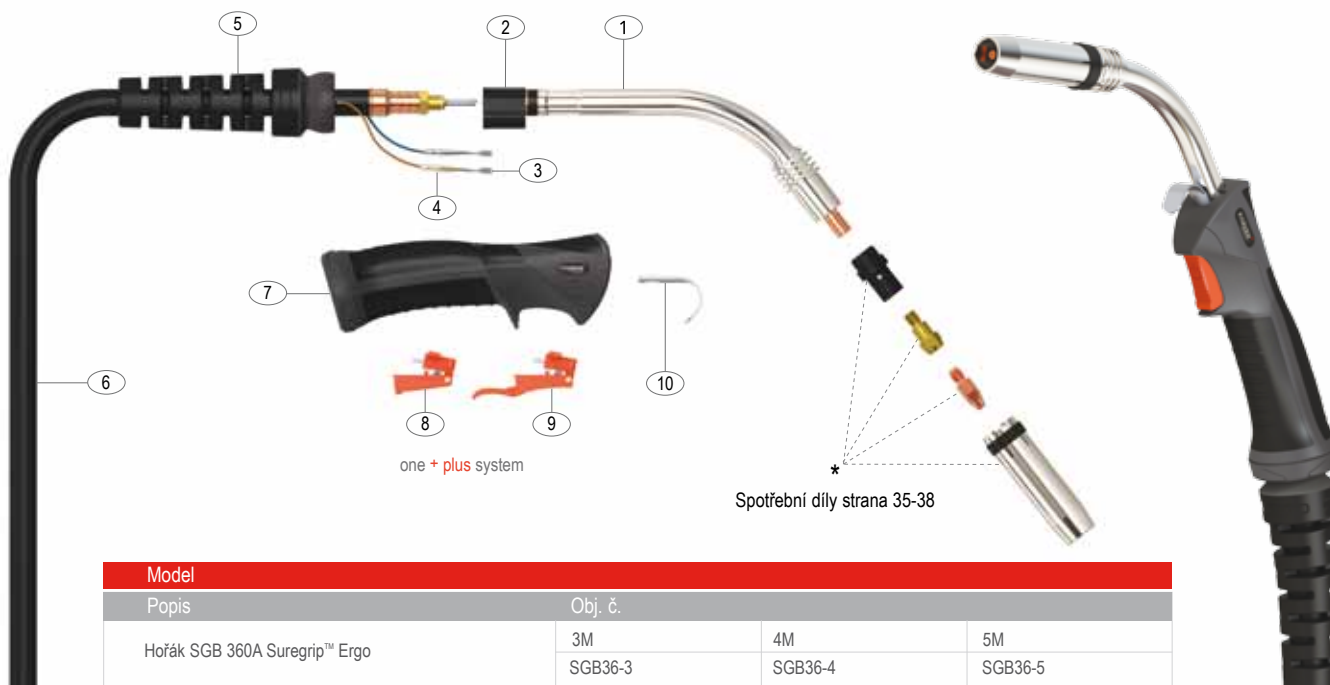

Model			
Popis	Obj. č.		
Hořák SGB 360A Suregrip™ Ergo	3M	4M	5M
	SGB36-3	SGB36-4	SGB36-5

Náhradní díly			
Obj. č.	Popis	Obj. č.	Popis
1	PG3603	15	SC2578/L Kryt C/W
2	PG1515	16	PBL1541 Šroub
3	PB1521	17	PC1519/S Matice
4	PB1521-C	18	PB1523 Konektor Female
5	PG8016	19	PC1528 Zástrčka centrální
6	PS3609-30	20	PB1524 „O“ kroužek
	PS3609-40	21	PB1525 Matice bovdeny
	PS3609-50		
7	SGB2514		
8	DGB2516		
9	DGB2516L		
10	PB2517		
11	PA3541		
12	PB1505		
13	PB1522		
14	SCSP1-1		

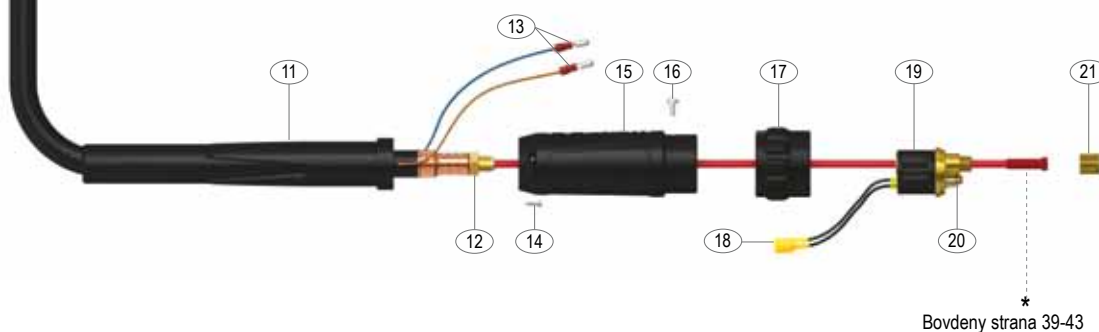

ALFA IN a.s., technická podpora
a centrální sklad pro Českou republiku a Slovensko

www.alfain.eu

obchod@alfain.eu

tel. 568 840 009

SGB 240W

Vodou chlazený svařovací hořák MIG
 Jmenovitý proud: 300A CO₂ 270A směsný plyn, EN60974-7 @ DZ = 100%, Ø drátu 0,8 do 1,2 mm

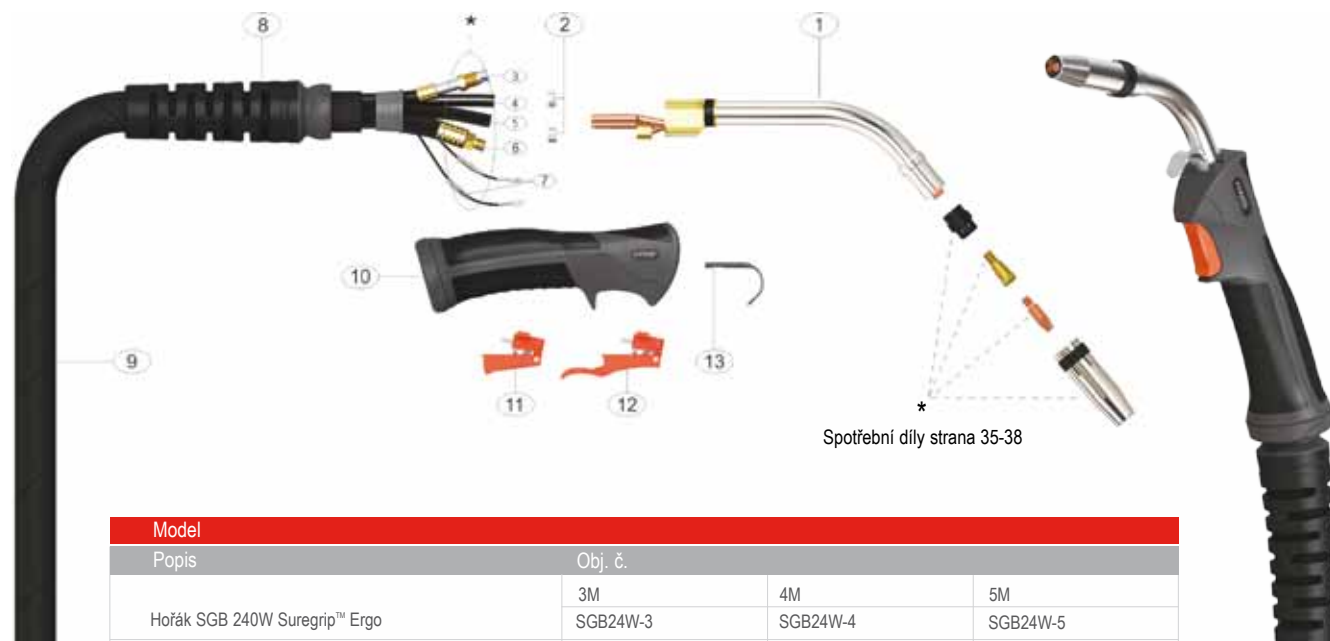

Model			
Popis	Obj. č.		
Hořák SGB 240W Suregrip™ Ergo	3M	4M	5M
	SGB24W-3	SGB24W-4	SGB24W-5

Náhradní díly			
Obj. č.	Popis	Obj. č.	Popis
1	PG2409	21	PBD-80310
	Trubka hořáku	22	PBD-80320
2	PB5041	23	PS5017
	Svorka na hadice 8,7mm	24	PB1526
8	PG3208	25	PB1519/S
	Ochrana kabelu	26	PB1522
9	PS4006-30	27	PB5024
	Kabel koax. X 3m	28	PB1523
	PS4006-40	29	PB5098
	Kabel koax. X 4m	30	PB1524
	PS4006-50	31	PB1525
	Kabel koax. X 5m		
10	SGB2514		
	Rukojeť ERGO		
11	DGB2516		
	Tlačítko standard		
12	DGB2516L		
	Tlačítko prodloužené		
13	PB2517		
	Hák závěsný		
14	PC8027		
	Pouzdro		
15	PT8028		
	Chránič kabelu NUT		
16	PT8009		
	Svorka		
17	PT8010		
	Díl upínací		
18	PT5022		
	Kryt		
19	PSLH1820-S		
	Průchodka pro hadičky		
20	PB5023		
	Rychlospojka vodní hadice		



Bovdeny strana 39-43

Suregrip™ Ergo MIG/MAG hořák

SGB 401W

Vodou chlazený svařovací hořák MIG
Jmenovitý proud: 400A CO₂, 350A směsný plyn, EN60974-7 @ DZ = 100%, Ø drátu 0,8 do 1,2 mm

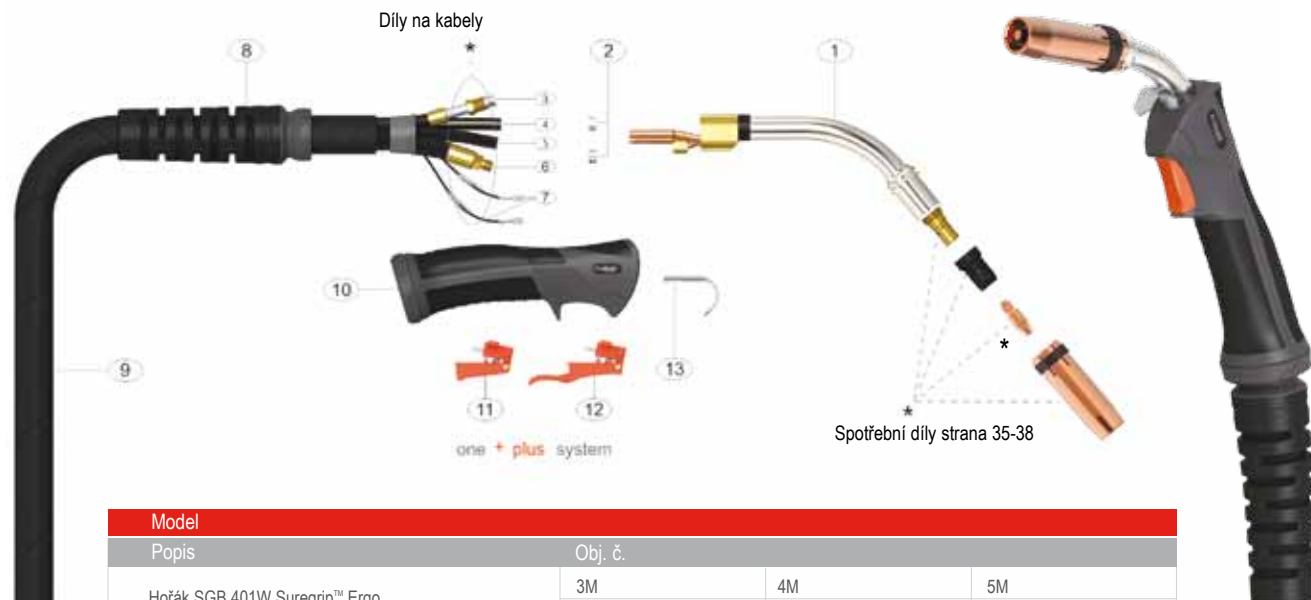

Model			
Popis	Obj. č.		
Hořák SGB 401W Suregrip™ Ergo	3M SGB401-3	4M SGB401-4	5M SGB401-5

Náhradní díly			
Obj. č.	Popis	Obj. č.	Popis
1	PG4011 Trubka hořáku	23	PS5017 Hadice vodní
2	PB5041 Svorka 8,7 mm	24	PB1526 Šroub
8	PG3208 Ochrana kabelu	25	PB1519/S Matice
9	PS4006-30 Kabel koax. X 3M	26	PB1522 Kabel - terminal Male
	PS4006-40 Kabel koax. X 4M	27	PB5024 Svorka 9,5 mm
	PS4006-50 Kabel koax. X 5M	28	PB1523 Konektor Female
10	SGB2514 Rukojeť	29	PB5098 Zástrčka centrální
11	DGB2516 Tlačítko standard	30	PB1524 „O“ kroužek
12	DGB2516L Tlačítko prodloužené	31	PB1525 Matice bovdeny
13	PB2517 Háček závěsný		
14	PC8027 Pouzdro		
15	PT8028 Chráníč kabelu		
16	PT8009 Svorka		
17	PT8010 Díl upínací		
18	PT5022 Kryt		
19	PSLH1820-S Průchodka pro hadičky		
20	PB5023 Rychlospojka hadice		
21	PBD-80310 Uzávěr hadice modrý		
22	PBD-80320 Uzávěr hadice červený		

Díly na kabely			
Popis	Obj. č.		
	3M	4M	5M
3 Vodič bovdeny	PS5008-30	PS5008-40	PS5008-50
4 Hadice plyn.	PS5013-30	PS5013-40	PS5013-50
5 Hadice vodní	PS5012-30	PS5012-40	PS5012-50
6 Kabel proudový	PS4015-30	PS4015-40	PS4015-50
7 Vodič	PS5010-30	PS5010-40	PS5010-50

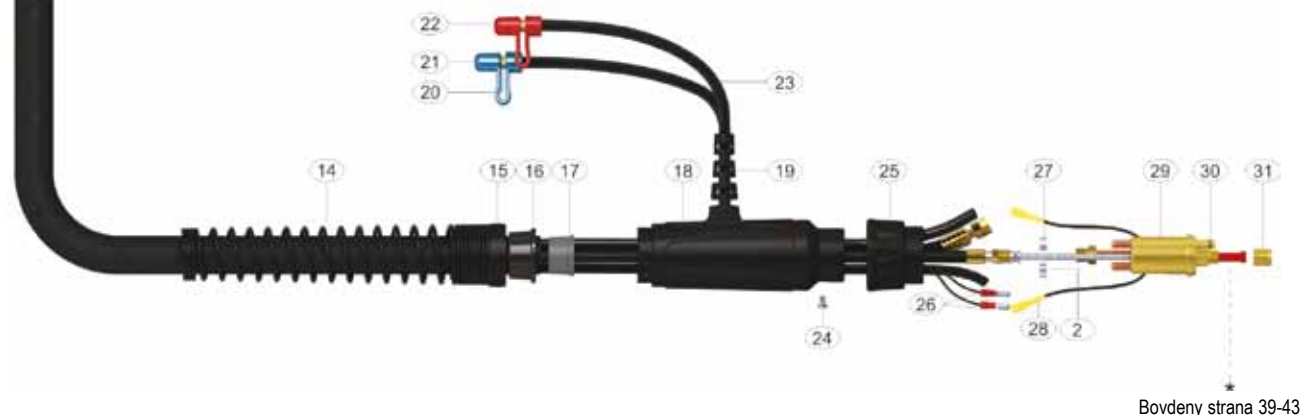

SGB 501W

Vodou chlazený svařovací hořák MIG

Jmenovitý proud: 500A CO₂ 450A směsný plyn, EN60974-7 @ DZ = 100%, Ø drátu 1,0 do 1,6 mm

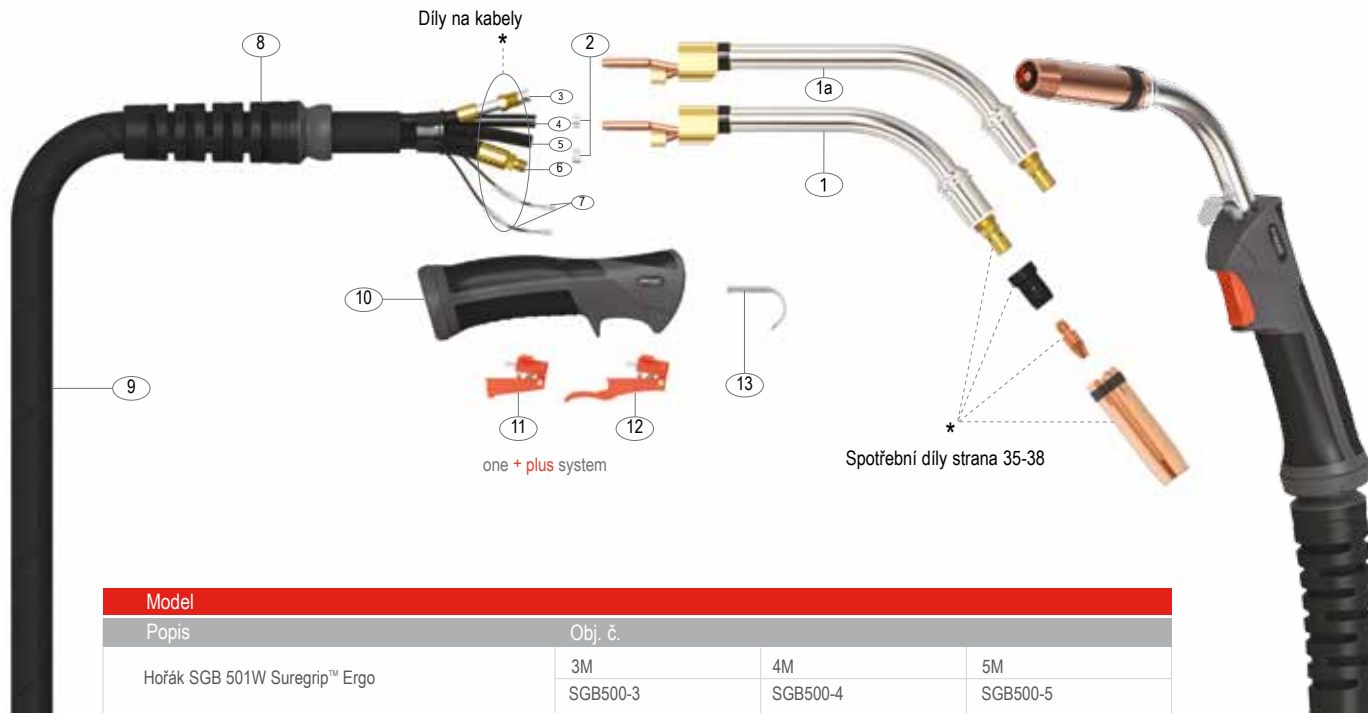

Model			
Popis	Obj. č.		
Hořák SGB 501W Suregrip™ Ergo	3M SGB500-3	4M SGB500-4	5M SGB500-5

Náhradní díly			
Obj. č.	Popis	Obj. č.	Popis
1	PG5002	23	PS5017
	Trubka hořáku		Hadice vodní
1a	PG5002L	24	PB1526
	Trubka hořáku dlouhá		Šroub
2	PB5041	25	PB1519/S
	Svorka 8,7 mm		Matice
8	PG3208	26	PB1522
	Ochrana kabelu		Kabel - terminal Male
9	PS5006-30	27	PB5024
	Kabel koax. X 3M		Svorka 9,5 mm
	PS5006-40	28	PB1523
	Kabel koax. X 4M		Konektor Female
	PS5006-50	29	PB5098
	Kabel koax. X 5M		Zástrčka centrální
10	SGB2514	30	PB1524
	Rukojeť ERGO		„O“ kroužek
11	DGB2516	31	PB1525
	Tlačítko standard		Matice bovdeny
12	DGB2516L		
	Tlačítko prodloužené		
13	PB2517		
	Hák závěsný (Optional Extra)		
14	PC8027		
	Pouzdro		
15	PT8028		
	Chráníč kabelu Nut		
16	PT8009		
	Svorka		
17	PT8010		
	Díl upínací		
18	PT5022		
	Kryt		
19	PSLH1820-S		
	Průchodka pro hadičky		
20	PB5023		
	Rychlospojka hadice		
21	PBD-80310		
	Uzávěr hadice modrý		
22	PBD-80320		
	Uzávěr hadice červený		

Díly na kabely			
Popis	Obj. č.		
	3M	4M	5M
3 Vodič bovdeny	PS5008-30	PS5008-40	PS5008-50
4 Hadice plyn.	PS5013-30	PS5013-40	PS5013-50
5 Hadice vodní	PS5012-30	PS5012-40	PS5012-50
6 Kabel proudový	PS5015-30	PS5015-40	PS5015-50
7 Vodič	PS5010-30	PS5010-40	PS5010-50

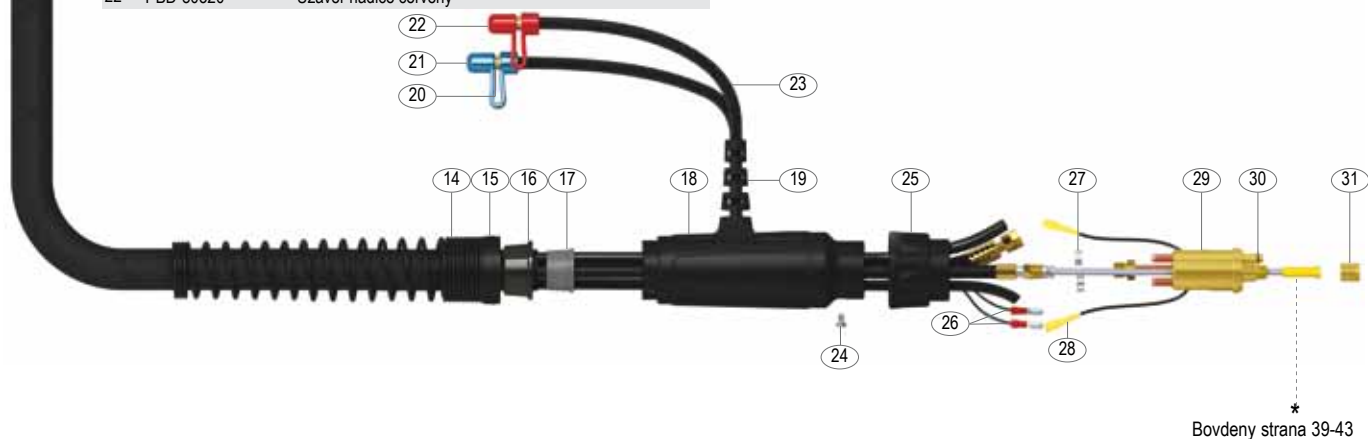

Suregrip™ Ergo MIG/MAG hořák

SGB 555W Vodou chlazený svařovací hořák MIG
Jmenovitý proud: 550A CO₂, 500A směsný plyn, 400A pulse, EN60974-7 @ DZ = 100%, Ø drátu 1,0 do 1,6 mm

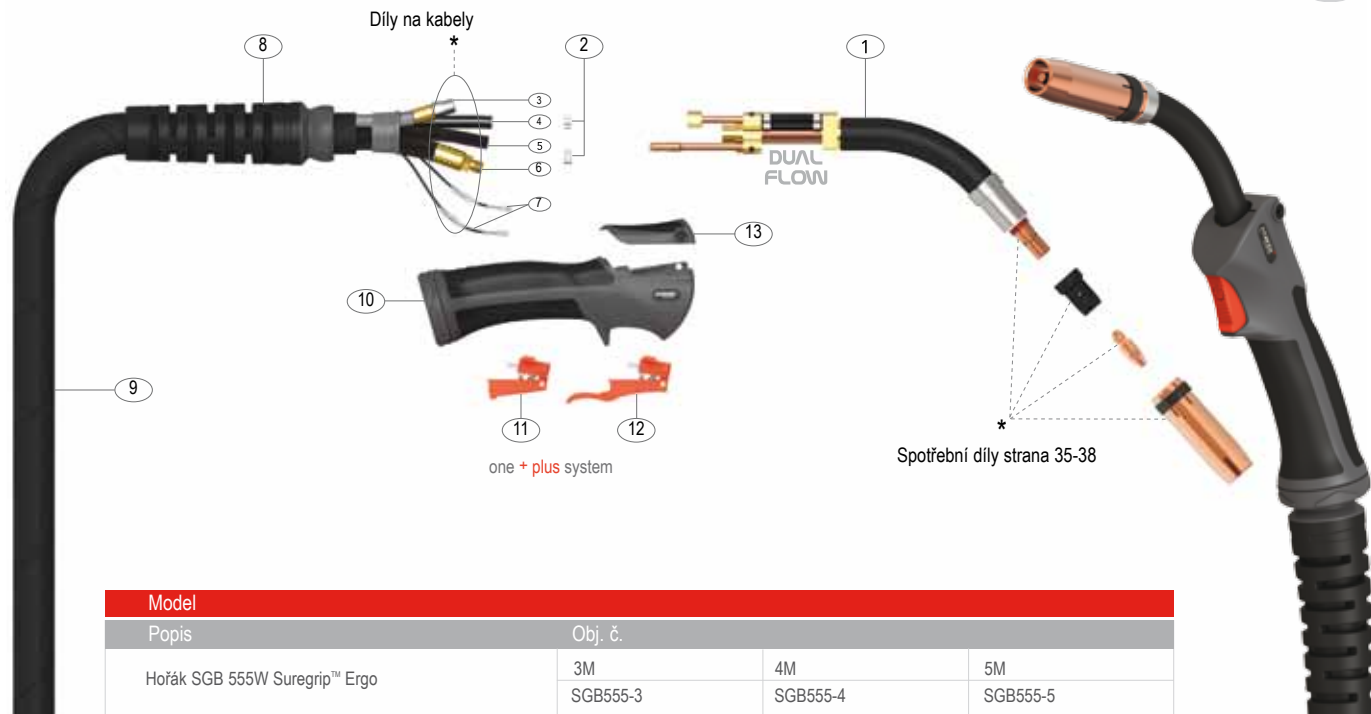

Model			
Popis	Obj. č.		
Hořák SGB 555W Suregrip™ Ergo	3M SGB555-3	4M SGB555-4	5M SGB555-5

Náhradní díly			
Obj. č.	Popis	Obj. č.	Popis
1	PB5502 Trubka hořáku	23	PS5017 Hadice vodní
2	PB5041 Svorka 8,7 mm	24	PB1526 Šroub
8	PG3208 Ochrana kabelu	25	PB1519/S Matice
9	PS5506-30 Kabel koax. X 3M	26	PB1522 Kabel - terminal Male
	PS5506-40 Kabel koax. X 4M	27	PB5024 Svorka 9,5 mm
	PS5506-50 Kabel koax. X 5M	28	PB1523 Konektor Female
10	SGM2515/KJ Rukojeť	29	PB5098 Zástrčka centrální
11	DGBH2516 Tlačítko standard	30	PB1524 „O“ kroužek
12	DGBH2516L Tlačítko prodloužené	31	PB1525 Matice bovdeny
13	PDM0 Horní díl rukojeti		
14	PC8027 Pouzdro		
15	PT8028 Chráníč kabelu		
16	PT8009 Svorka		
17	PT8010 Díl upínací		
18	PT5022 Kryt		
19	PSLH1820-S Průchodka pro hadičky		
20	PB5023 Rychlospojka hadice		
21	PBD-80310 Uzávěr hadice modrý		
22	PBD-80320 Uzávěr hadice červený		

Díly na kabely				
Popis	Obj. č.			
3	Vodič bovdeny	3M PS5508-30	4M PS5508-40	5M PS5508-50
4	Hadice plyn.	PS5013-30	PS5013-40	PS5013-50
5	Hadice vodní	PS5012-30	PS5012-40	PS5012-50
6	Kabel proudový	PS5515-30	PS5515-40	PS5515-50
7	Vodič	PS5010-30	PS5010-40	PS5010-50

